



**82<sup>nd</sup> ANNUAL SANIBEL SHELL SHOW**  
**MARCH 7, 8, 9, 2019**  
**SANIBEL COMMUNITY HOUSE - SANIBEL, FLORIDA**



Dear Exhibitor,

The Sanibel-Captiva Shell Club invites you to participate in the 82<sup>nd</sup> Annual Shell Show, the highlight of the Sanibel Shell Festival.

As always, please read these rules carefully because there have been several changes and additions since last year. We want to ensure that your exhibit qualifies for the class you are entering and meets the size limitations and other requirements. If you have any questions, please contact the chairperson of the division you are entering.

The show will run for three days - Thursday March 7<sup>th</sup>, Friday March 8<sup>th</sup> and Saturday March 9<sup>th</sup>. The hours of the show are 9:00 AM to 5:00 PM March 7<sup>th</sup> and 8<sup>th</sup> and 9:00 AM to 4:00 PM March 9<sup>th</sup>.

Entry forms are accepted in the order the Artistic and Scientific Exhibit Chairpersons receive them. Their addresses can be found on the entry forms. **The Division Chairpersons reserve the right to limit the number of items per exhibitor if entries exceed the available space.** All **Artistic Division** entry forms must be received by **February 14, 2019**. All **Scientific Division** entry forms must be received by **February 18, 2019**. Entries in both Divisions will no longer be accepted once the available exhibition space has been exceeded. For specific information and rules for the Scientific Division, see page 3, for the Artistic Division, see page 4.

Show entries must be brought to the **Sanibel Community House, 2173 Periwinkle Way, on Tuesday, March 5<sup>th</sup> between 9:00 AM and 4:00 PM**. Because parking is limited at the Community House, please move your vehicle to the parking area across the street as soon as your exhibits are unloaded.

All exhibits must be removed on Saturday, March 9<sup>th</sup> between 4:15 PM and 6:00 PM

The judges for the 82<sup>nd</sup> Annual Sanibel Shell Show are as follows:

- Scientific Division: David Green, Houston, Texas  
 Duane Kauffman, Sarasota, Florida & Goshen, Indiana
- Artistic Division: Marci Chamberlin, Palm Beach, Florida and Andover, Massachusetts  
 Linda Koestel Green, Houston Texas

The Judges and Awards Reception will be held at The Bailey-Matthews Shell Museum on Wednesday, March 6<sup>th</sup> at 5:30 PM. Seating is limited and tickets are sold on a first-come, first-serve basis. After the reception, those in attendance will be invited to a sneak preview of the show. Only those persons purchasing tickets to the reception will be allowed in the Community Building that night. Information regarding the reception can be found on the last page of this document.

We sincerely thank you for entering your exhibit in the 82<sup>nd</sup> Sanibel Shell Show and we look forward to your participation. If you have any questions, please contact us.

- |   |   |                                  |   |
|---|---|----------------------------------|---|
| Mary Burton, Artistic Division Chairperson<br>and Shell Show Co-Chairperson | Before November 1 <sup>st</sup><br>After November 1 <sup>st</sup> | (207) 354-2602<br>(239) 395-3626 | <a href="mailto:marybsanibel@hotmail.com">marybsanibel@hotmail.com</a><br>Cell 561-301-2971 |
| Joyce Matthys, Shell Show Co-Chairperson                                    |   | (503) 871-1082                   | <a href="mailto:joycematthys1@gmail.com">joycematthys1@gmail.com</a>                        |
| Tom Annesley, Scientific Division Chairperson                               |   | (734)-660-3648                   | <a href="mailto:annesley@med.umich.edu">annesley@med.umich.edu</a>                          |

Kathy Kapp, President  
 Sanibel-Captiva Shell Club

9/21/2018

## 2019 SANIBEL SHELL SHOW RULES

### GENERAL RULES – Applicable to both Scientific and Artistic Division Exhibits

1. Exhibitor may enter more than one class, but only one entry per class.
2. Entry applications are accepted on a space-available basis. They will be accepted in the order in which they are received. It is the responsibility of the exhibitor to select the appropriate entry class. Entry class may not be changed after the Application Due Date except with approval of the Division Chairperson.
3. The contents of each exhibit must be the property of the exhibitor – no borrowed specimens or art pieces. When an exhibit is a collaboration, the names of all exhibitors shall appear on the entry forms.
4. Because judging is anonymous, the exhibitor's name must not be visible on any exhibit until after judging is completed. This is especially pertinent to the artist's name or initials on individual artistic exhibit items.
5. Exhibitors shall check in and set up exhibits at the **Sanibel Community House at 2173 Periwinkle Way only between the hours of 9:00 AM and 4:00 PM on Tuesday, March 5<sup>th</sup>, 2019**. Each exhibitor is responsible for obtaining his/her own help on carrying in his/her exhibit(s). Exhibitors must move their vehicle to the parking lot across the street after unloading. Immediately after setting up exhibits, exhibitors **must exit** the display rooms unless he/she is working with a Chairperson of the Shell Show. If an exhibitor cannot check in until after 4:00 PM, the exhibitor may make special arrangements with the Division Chairperson to check in later.
6. Arrangement and exact placement of exhibits will be determined by Shell Show officials and not by exhibitors. Accordingly, no exhibitor shall move or otherwise handle another's exhibit. Also, exhibitors will not handle their own exhibits while the show is open to the public without permission from the Shell Show Chairperson.
7. During the show, no exhibit or portion thereof may be removed. **Anyone removing an exhibit prior to the show closing will be excluded from exhibiting in future shell shows.**
8. Exhibitors must remove all exhibits **between the hours of 4:15 PM and 6:00 PM on Saturday, March 9<sup>th</sup>**. Please note the 4:15 PM time. We allow 15 minutes to clear the public and exhibitors for an orderly takedown. Scientific Exhibitors must re-enter through the west facing double doors. Artistic Exhibitors must re-enter through the double doors facing Periwinkle Way. **Exhibitors must inform Shell Show officials if someone other than the exhibitor is removing their exhibit. Shell Show officials will remove exhibits not removed by 6:00 PM. Exhibitor will then be responsible for retrieval of his/her exhibit.** Exhibitor is responsible for obtaining his/her own help on carrying out his/her exhibit(s).
9. Evaluation of the merits of exhibits and the giving of awards is solely the responsibility of the judges, whose decisions will be final. Awards in each class will be given only to the extent that judges determine exhibits are of sufficient merit.
10. Noncompetitive exhibits may be entered in the show with permission of and at the **sole discretion of the Division Chairperson**. They will be allowed only on a space-available basis with priority always given to competitive exhibits.
11. **Suggestions or complaints concerning the show must be directed to the Shell Show Chairpersons only. Any unsportsmanlike conduct on the part of any exhibitor will be discussed at the next meeting of the Sanibel-Captiva Shell Club Board of Directors and appropriate action will be taken, including possible expulsion from future shows for a minimum of one year or perhaps longer.**

**SCIENTIFIC DIVISION RULES – Applicable to Scientific Division Exhibits only.**

12. **All scientific exhibit tables are 2 feet 6 inches (30 inches) deep, front to back.**
13. Total exhibit width is not limited. Exhibits exceeding 40 feet in width will be exhibited in two parts as determined by the Scientific Chairperson. If your exhibit width exceeds 40 feet, please indicate on your entry form the prioritized possibilities for dividing your exhibit into two parts. Every effort is made to avoid dividing exhibits under 40 feet in width.
14. If an exhibit includes an upright poster or panel, its height from tabletop shall not exceed 36 inches, including stands or supports, and its back shall be plain and finished, preferably in a dark color, so as not to detract from exhibits on the other side of the back-to-back tables.
15. **Exhibits must be in enclosed cases** that may be locked during show. They should be unlocked for judging so that judges can remove and examine individual specimens, as they deem necessary. If the exhibitor chooses to keep the exhibit cases locked during judging, he/she recognizes that his/her exhibit may receive a lesser award if judges wanted, but were unable, to remove specimens for examination. A single specimen within an exhibit in any class that is too large to be in an enclosed case may be entered with approval of the Scientific Chairperson.
16. Specimens must not be sprayed or coated with acrylic, lacquer or other artificial glazes.
17. An exhibit that received a First Place Award at a previous Sanibel Shell Show is ineligible as a competitive exhibit in the same category, unless that exhibit is more than fifty percent new.
18. "Self-collected" means personally collected from the species' natural habitat; personally retrieved on a boat from a trap, net or dredge; or personally retrieved on shore from beach drift or scallop dump. "Self-collected" does not include loaned, gifted, purchased or traded specimens. "Self-collected" specimens may be designated by a red star or dot on the label if they are not in a self-collected exhibit class.
19. All specimens must be labeled with full scientific name (genus, species or subspecies, author, date) and locality where collected. A diagrammatic chart, like the sample below may be used for labeling.

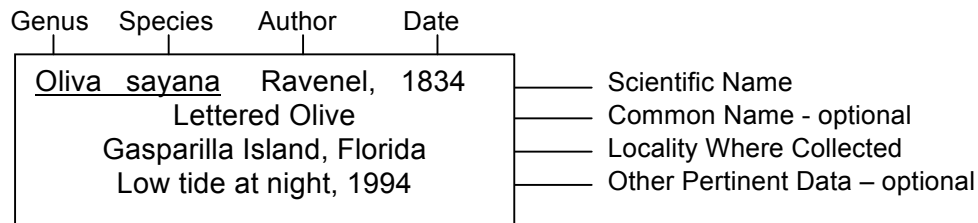

Genus & Species: The Latin or Latinized names are underlined or in italic. The genus name is capitalized. The species name is not capitalized. Leave space between genus and species name as shown above.

Author & Date: The person who first described and named the species and the year of authorship. When author and date are in parenthesis, it means that the species has been reclassified into a genus different from the one in which the author originally placed it.

**NOTE: Remember to add a brief description of your exhibit(s) on the entry form in the space provided following the measurements of your exhibit. This is to help us insure that your exhibit is in the right class.**

**ARTISTIC DIVISION RULES – Applicable to Artistic Division Exhibits only.**

20. **All artistic exhibit tables are 2 feet 6 inches (30 inches) deep, front to back.**
21. Exhibits must be entirely the work of the exhibitor. No kits allowed. When an exhibit is a collaboration, the names of all exhibitors must appear on the entry form.
22. Exhibitor will provide the following: any needed easel, stand, etc. for tabletop exhibits; picture wire hanger on wall hung exhibits (no saw-tooth hangers are permitted.) and a 12-foot extension cord for electric exhibits. Sailor's valentines should be displayed on a secure stand or easel.
23. **Tabletop easel is required.** Class 59, 60, 63, 90, 91 and 94 require a tabletop easel not to exceed 15 inches in depth or 2 inches wider or higher than the exhibit being displayed.
24. Exhibits must consist mainly of shells and/or other sea life except Classes 63 & 94 that do not allow shells, and Classes 50 & 80 that do not require shells. Exhibits in Classes 50, 63, 80 & 94 must have a shell theme as their primary content.
25. A professional exhibitor is one who has sold, or offered for sale, his/her work through galleries, shops, shows, at home or any other outlets, whether he/she has a tax number and regardless of total sales volume or income.
26. Exhibits without dimensions on the entry form will **NOT** be accepted. Make sure they are on your entry form.
27. An exhibit that received a First Place Award at a previous Sanibel Shell Show is ineligible as a competitive exhibit in the same category, unless that exhibit is more than fifty percent new.
28. A professional exhibitor may exhibit in a hobbyist class provided the exhibit is a medium that is substantially and clearly different from the exhibitor's professional medium or media. For example: One who has made and sold sailor's valentines, mosaics, and/or flowers but has never sold photographs or needlework may enter his/her photographs or needlework in a hobbyist class.
29. **A photograph of each artistic exhibit is required.** Photographs help the Artistic Chairperson determine if the exhibit has been entered in the correct class and meets the requirements. They also help eliminate the stress of having to rearrange exhibits on the Shell Show setup day. Please include a photograph of your exhibit(s) so we can complete the application process and confirm that your space in the show has been reserved. If your exhibit has not been completed when you submit your entry, please submit a photo by February 14<sup>th</sup>. **Entries without a photograph will NOT be accepted.** Photographs are used **solely** to determine if the exhibit is in the correct class.
30. **No-Show Rule:** If for some reason you will not be exhibiting all the entries listed on your entry form, you must contact the Artistic Chairperson on or before February 14, 2019, and identify the exhibits being withdrawn. Likewise, you must contact the Artistic Chairperson if you are not going to participate in the show. Should you fail to send notification by the deadline that you are not bringing all the exhibits listed on your entry form or you are not going to participate in the show, you will be considered a "No-Show" and will be issued a "No-Show Warning." A second "No-Show Warning" will result in a restriction that will prevent you from entering the show for a period of one year.
31. **Exhibit Description Placard** is limited to 4" x 6". A placard exceeding this size will be removed.
32. **After judging is complete, professional artistic exhibitors may display business cards next to their exhibit at a cost of \$50 per exhibit.** If your exhibit will be hung on the wall, please provide a holder that can be attached to the hanging chain. Please make your check payable to the Sanibel-Captiva Shell Club and include it with your entry form or mail it to Sanibel-Captiva Shell Club, P.O. Box 355, Sanibel Island, Florida 33957. No exhibit may be sold during the show with the exception of the work of commercial vendors.

Note: Artistic exhibits will be judged on the following criteria:

1. Quality of craftsmanship - 50%
2. Quality and choice of material used - 25%
3. Arrangement, beauty and originality of creation - 25%

**EXHIBIT DIMENSIONS**

A = HEIGHT  
 B = DEPTH  
 C = WIDTH

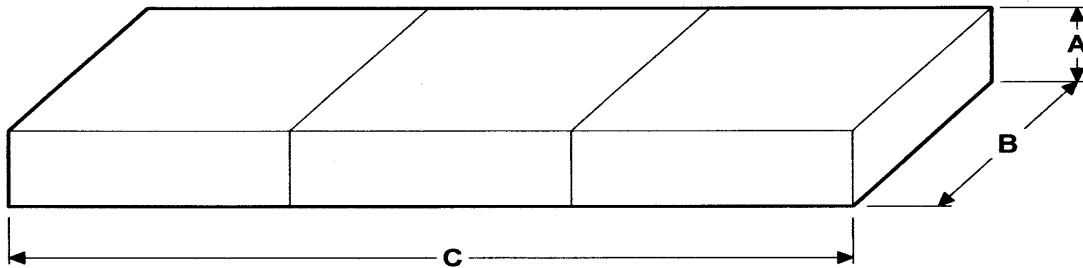

**DISPLAY CASES**

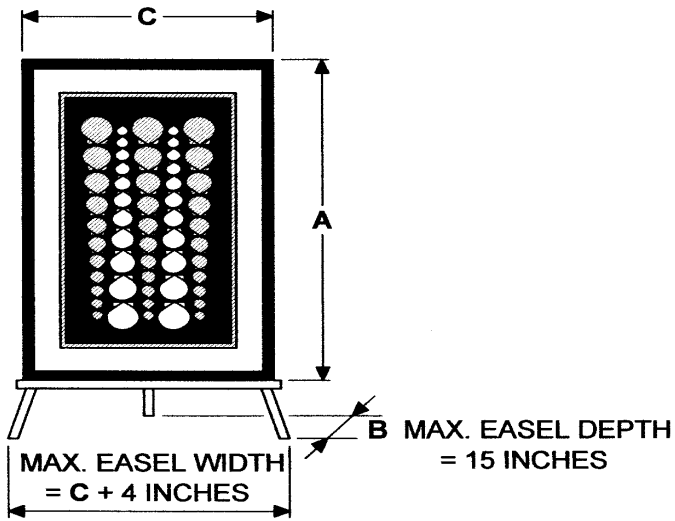

**TABLETOP EASEL**  
 - FLOWER PICTURE  
 - PICTURE OR MOSAIC  
 - MULTIMEDIA

**MUST BE HUNG BY WIRE  
 NO SAW-TOOTH HANGERS**

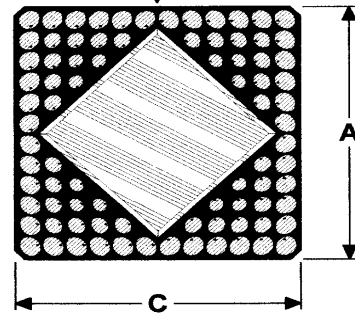

**WALL HUNG**  
 - MIRROR  
 - WREATH, NON-HOLIDAY

**EXHIBIT CLASSES – SCIENTIFIC DIVISION  
2019 SANIBEL SHELL SHOW**

**See General Rules 1 through 11 and Scientific Rules 12 through 19**

**YOUNG SCIENTIST CLASSES**

1. GRADES K-6. Shells and/or sea life. Multiple or single shell. Worldwide. Any source
2. GRADES 7-12. Shells and/or sea life. Multiple or single shell. Worldwide. Any source

**SINGLE SHELL CLASSES – One specimen only**

3. SANIBEL-CAPTIVA – Self-collected
4. FLORIDA-CARIBBEAN – Self-collected
5. FLORIDA-CARIBBEAN – Any source
6. WORLDWIDE – Self-collected
7. WORLDWIDE – Any source
8. UNUSUAL VARIANTS (Albino, freak, etc.) – Any source
9. FOSSIL (Shells and/or other Sea Life) – Any source
10. SEA LIFE (other than shells) – Coral, echinoderm, etc. – Any source

**MULTIPLE SHELL CLASSES – Two or More Specimens**

11. SANIBEL-CAPTIVA – Self-collected
12. FLORIDA-CARIBBEAN – Self-collected
13. FLORIDA-CARIBBEAN – Any source
14. WORLDWIDE – Any source
15. ONE SUPERFAMILY or FAMILY or SUBFAMILY – Any source
16. ONE GENUS – Any source
17. ONE SPECIES to show COLOR, FORM and/or GROWTH – Self-collected
18. ONE SPECIES to show COLOR, FORM and/or GROWTH – Any source
19. EDUCATIONAL. Intended primarily to teach. Any source
20. LAND or FRESH WATER SHELLS – Any source
21. UNUSUAL VARIANTS (Albino, freak, etc.) – Any source
22. FOSSILS (Shells and/or other Sea Life)– Any source
23. SEA LIFE OTHER THAN SHELLS – Coral, echinoderm, etc. – Any source
24. SPECIAL – An exhibit that does not fit into any of the above classes
25. MINIATURES – Adult shells only, maximum size 1 inch. May be a general, regional, or specialized collection

**SINGLE SHELL OR MULTIPLE SHELL CLASS**

26. BEST OF THE BLUES. Limited to any exhibit that has previously won a Blue Ribbon at any past Sanibel Shell Show. These exhibits are eligible for the du Pont Trophy and the Conchologists of America Award.
27. ANNE JOFFE SANIBEL SUPERSTAR AWARD. Limited to exhibits that have previously won any major award, such as du Pont, C.O.A., Smithsonian or American Museum of Natural History Award, Masters, Mote Gold, or Clench at any shell show.

**SCIENTIFIC DIVISION SPECIAL AWARDS  
2019 SANIBEL SHELL SHOW**

**DU PONT TROPHY**

Most outstanding entry in Classes 1 - 26. Sponsored by the Delaware Museum of Natural History.

**CONCHOLOGISTS OF AMERICA AWARD**

Entry that best furthers interest in shells and shell collecting in Classes 1 - 26. Sponsored by Conchologists of America.

**BEST SANIBEL-CAPTIVA SHELLS – SELF-COLLECTED**

Best Sanibel-Captiva shells in any class.

**BEST FLORIDA-CARIBBEAN SHELLS – ANY SOURCE**

Best Florida-Caribbean shells, any source. Classes 12 and 13

**HOWARD SEXAUER AWARD**

Best worldwide shells, any source, in Class 14.

**BEST FOSSILS– ANY SOURCE**

Best exhibit in class 22.

**MARILYN NORTHROP AWARD: SHELL OF SHOW – SELF-COLLECTED**

Best self-collected single shell included in any exhibit.

**EUGENE AND EVELYN SPENCER AWARD**

Best single South Pacific Shell in any exhibit.

**SHELL OF SHOW: ANY SOURCE**

Best single shell in any exhibit.

**SHELL OF SHOW: FOSSIL**

Best single shell fossil included in any exhibit.

**ELSIE MALONE AWARD**

Best Young Scientist Exhibit – Classes 1 and 2.

**BEST OF THE BLUES**

Best entry in Class 26.

**ANNE JOFFE SANIBEL SUPERSTAR AWARD**

Best entry in Class 27.

**R. TUCKER ABBOTT AWARD**

The scientific exhibit that best exemplifies world wide educational interest in shells.

**PEOPLES' CHOICE AWARD – SCIENTIFIC**

Scientific entry voted most outstanding by the public.

**JUDGE'S SPECIAL RIBBONS**

One award by each scientific judge to any scientific exhibit.

**JUDGES' MERIT RIBBON**

Awarded to a non-blue-ribbon scientific exhibit that both judges agreed was noteworthy of recognition.

**SCIENTIFIC DIVISION ENTRY FORM  
2019 SANIBEL SHELL SHOW**

• Early **DECEMBER** address • Please print •

NAME: \_\_\_\_\_

MAILING ADDRESS: \_\_\_\_\_

CITY: \_\_\_\_\_ STATE: \_\_\_\_\_ ZIP: \_\_\_\_\_

PHONE (December) \_\_\_\_\_ PHONE (February) \_\_\_\_\_

E-MAIL: \_\_\_\_\_

If you are age seventeen or under, indicate age and grade: \_\_\_\_\_

LEAVE BLANK	CLASS NUMBER	NO. OF CASES	OVERALL EXHIBIT SIZE			DESCRIPTION OF EXHIBIT & MAJOR AWARDS WON FROM OTHER SHELL SHOWS, IF ANY
			HEIGHT (A)	DEPTH (B)	WIDTH (C)	

If entering Class 28, indicate below the award (du Pont, COA, Smithsonian, etc.) that qualifies your exhibit for entry, and the show and year in which the award was conferred.

AWARD: \_\_\_\_\_ SHOW: \_\_\_\_\_ YEAR: \_\_\_\_\_

I have read the Shell Show Rules and agree to abide by them. I understand that the Sanibel Community Association and the Sanibel-Captiva Shell Club accept no responsibility for loss or damage of any exhibit or part thereof.

SIGNED: \_\_\_\_\_ DATE: \_\_\_\_\_

Is this your first time exhibiting at the Sanibel Shell Show? YES: \_\_\_\_\_ NO: \_\_\_\_\_

Can you volunteer for two hours as a shell show host? IF YES, WHEN \_\_\_\_\_

• EMAIL OR MAIL SCIENTIFIC ENTRY FORM TO ADDRESS BELOW •

Tom Annesley, 16245 Coco Hammock Way #102, Ft. Myers, FL 33908 734-660-3648  
annesley@med.umich.edu

**ENTRY FORM MUST BE RECEIVED BY FEBRUARY 18, 2019**



**HOBBYIST EXHIBIT CLASSES – ARTISTIC DIVISION  
2019 SANIBEL SHELL SHOW**

See General Rules 1 through 11 and Artistic Rules 20 through 32

40. **FLOWER ARRANGEMENT MADE OF SHELLS.** Shells only. Maximum 30 in. high x 24 in. wide. Tabletop only.
41. **FLOWER ARRANGEMENT.** Sea life with or without shells. Maximum 30 in. high x 24 in. wide. Tabletop only.
42. **SINGLE FLOWER.** Shells and/or sea life. Tabletop only.
43. **SINGLE STEM OF FLOWERS.** Shells and/or sea life. Tabletop only.
44. **MINIATURE FLOWER ARRANGEMENT.** Shells and/or sea life. Maximum 3 in. x 3 in. x 3 in. Tabletop only. Presentation encouraged.
45. **MINIATURE PICTURE.** Shells and/or sea life. Maximum 6 in. x 8 in. Tabletop only.
46. **LAMP.** Single Lamp. Shells and/or sea life. Maximum 36 in. high x 24 in. wide. Tabletop only.
47. **TREE OR TOPIARY.** Single non-holiday tree or topiary. Shells and/or sea life. **NO LIGHTS.** Maximum 30 in. high x 24 in. wide. Tabletop only.
48. **JEWELRY.** Single piece of jewelry in a covered case. Shell and/or sea life related. Maximum 24 in. wide. Tabletop only.
49. **JEWELRY.** Multiple pieces of jewelry in a covered case. Shell and/or sea life related. Limited to 8 pieces. Maximum 24 in. wide. Tabletop only.
50. **SHELL-RELATED NEEDLECRAFT.** Includes all forms of sewing, quilting, knitting, needlepoint, small pieces of clothing etc. Shell and/or sea life related. No kits. Maximum 30 in. high x 24 in. wide. Tabletop only.
51. **HOLIDAY DECORATION.** Any holiday of your choice. Tree, wreath, picture, etc. Shells and/or sea life. Maximum 30 in. high x 24 in. wide. Tabletop only.
52. **SINGLE SAILOR'S VALENTINE.** Octagonal case. Shells and/or sea life. Minimum 7 inches. Maximum 32 inches. Tabletop only.
53. **SINGLE MINIATURE SAILOR'S VALENTINE.** Octagonal case. Shells and/or sea life. Three inches overall or smaller. Tabletop only.
54. **SINGLE MINIATURE SAILOR'S VALENTINE.** Octagonal case. Shells and/or sea life. 4 in. minimum to 6 in. maximum overall. Tabletop only.
55. **TRADITIONAL SINGLE SAILOR'S VALENTINE.** Octagonal case. Shells and/or sea life. Design to be created in the traditional Barbadian flat geometric Mosaic style incorporating cotton batting, paper dividers, majority of Caribbean shell types used, and other elements that were utilized in older valentines. Maximum 14 in. x 14 in. Tabletop only.
56. **DOUBLE SAILOR'S VALENTINE.** Pair of hinged octagonal cases. Shells and/or sea life. Heart and flowers on one side and sentimental message on the other side. Maximum 20 in x 40 in. Tabletop only.
57. **TRADITIONAL DOUBLE SAILOR'S VALENTINE.** Pair of hinged octagonal cases. Shells and/or sea life. Optional sentimental message and/or picture. Design to be created in the traditional Barbadian flat geometric Mosaic style incorporating cotton batting, paper dividers, majority of Caribbean shell types used, and other elements that were utilized in older valentines. Maximum 14 in. x 28 in. Tabletop only.
58. **NOVELTIES.** Animals, caricatures, etc. Shells and/or sea life. On single base or easel. Maximum 30 in. high x 24 in. wide. Tabletop only.
59. **FLOWER PICTURE.** Shells and/or sea life. Maximum 30 in. high x 24 in. wide. Tabletop easel required. See Artistic Rule 23.
60. **PICTURE OR MOSAIC OTHER THAN FLOWERS.** Shells and/or sea life. Maximum 30 in. high x 24 in. wide. Tabletop easel required. See Artistic Rule 23.
61. **MIRROR.** Shells and/or sea life. Maximum 30 in. high x 24 in. wide. May be a circle. Wall hung only.
62. **WREATH, NON-HOLIDAY.** Shells and/or sea life. Maximum 30 in. high x 24 in. wide. May be a circle, oval or heart shape with open center. Wall hung only.
63. **MULTIMEDIA.** Photo, painting, or other artistic rendering. Shell related. No actual shells. Maximum 30 in. high x 24 in. wide. Tabletop easel required. See Artistic Rule 23.
64. **SHELL TABLE.** Must utilize shells and/or sea life as a major component. **Minimum 16 in. high x 15 in. deep x 15 in. wide.** Maximum 36 in. high x 30 in. deep x 42 in. wide. Cannot have drawers. **Must set directly on the floor.**
65. **SHELL BOX.** Box must utilize shells and/or sea life as a major component. Maximum 12 in. x 24 in. Tabletop only.
66. **MISCELLANEOUS.** Not applicable to any of the other classes. Maximum 30 in. high x 24 in. wide. Tabletop only.
67. **YOUNG ARTIST – GRADES K-6.** Any of above Classes 40 through 65. Maximum 30 in. high x 24 in. wide. Tabletop only.
68. **YOUNG ARTIST – GRADES 7-12.** Any of above Classes 40 through 65. Maximum 30 in. high x 24 in. wide. Tabletop only.

**HOBBYIST AND PROFESSIONAL CLASS, OPEN TO BOTH ARTISTIC DIVISIONS  
2019 SANIBEL SHELL SHOW**

201. **COLLECTABLES.** Antiques, fine art, unusual artifacts, collectibles incorporating shells or shell motifs. Maximum size 18 in. high x 24 in. wide. If you have a larger piece you would like to exhibit, please contact Artistic Chairperson Mary Burton (marybsanibel@hotmail.com) for space availability. This class is open to hobbyists and professionals and must **NOT** be the work of the exhibitor. Tabletop only.

**PROFESSIONAL EXHIBIT CLASSES - ARTISTIC DIVISION  
2019 SANIBEL SHELL SHOW**

See General Rules 1 through 11 and Artistic Rules 20 through 32.

70. **FLOWER ARRANGEMENT MADE OF SHELLS.** Shells only. Maximum 30 in. high x 24 in. wide. Tabletop only.
71. **FLOWER ARRANGEMENT.** Sea life with or without shells. Maximum 30 in. high x 24 in. wide. Tabletop only.
72. **SINGLE FLOWER.** Shells and/or sea life. Tabletop only.
73. **SINGLE STEM OF FLOWERS.** Shells and/or sea life. Tabletop only.
74. **MINIATURE FLOWER ARRANGEMENT.** Shells and/or sea life. Maximum 3 in. x 3 in. x 3 in. Tabletop only. Presentation encouraged.
75. **MINIATURE PICTURE.** Shells and/or sea life. Maximum 6 in. x 8 in. Tabletop only.
76. **LAMP.** Single Lamp. Shells and/or sea life. Maximum 36 in. high x 24 in. wide. Tabletop only.
77. **TREE OR TOPIARY.** Single non-holiday tree or topiary. Shells and/or sea life. **NO LIGHTS.** Maximum 30 in. high x 24 in. wide. Tabletop only.
78. **JEWELRY.** Single piece of jewelry in a covered case. Shells and/or sea life related. Maximum 24 in. wide. Tabletop only.
79. **JEWELRY.** Multiple pieces of jewelry in a covered case. Shells and/or sea life related. Limited to 8 pieces. Maximum 24 in. wide. Tabletop only.
80. **SHELL-RELATED NEEDLECRAFT.** Includes all forms of sewing, quilting, knitting, needlepoint, small pieces of clothing, etc. Shell and/or sea life related. No kits. Maximum 30 in. high x 24 in. wide. Tabletop only.
81. **HOLIDAY DECORATION.** Any holiday of your choice. Tree, wreath, picture, etc. Shells and/or sea life. Maximum 30 in. high x 24 in. wide. Tabletop only.
82. **SINGLE SAILOR'S VALENTINE.** Octagonal case. Shells and/or sea life. 13 in. minimum to 32 in. maximum. Tabletop only.
83. **SINGLE MINIATURE SAILOR'S VALENTINE.** Octagonal case. Shells and/or sea life. Three inches overall or smaller. Tabletop only.
84. **SINGLE MINIATURE SAILOR'S VALENTINE.** Octagonal case. Shells and/or sea life. 4 in. minimum to 6 in. maximum overall. Tabletop only.
85. **SINGLE MEDIUM SAILOR'S VALENTINE.** Octagonal case. Shells and/or sea life. 7 in. minimum to 12 in. maximum. Composition must be entirely the work of the artist. Design must include a heart(s), and flowers. Tabletop only.
86. **TRADITIONAL SINGLE SAILOR'S VALENTINE.** Octagonal case. Shells and/or sea life. Design to be created in the traditional Barbadian flat geometric Mosaic style incorporating cotton batting, paper dividers, majority of Caribbean shell types used, and other elements that were utilized in older valentines. Maximum 14 in. x 14 in. Tabletop only.
87. **DOUBLE SAILOR'S VALENTINE.** Pair of hinged octagonal cases. Shells and/or sea life. Heart and flowers on one side and sentimental message on the other side. Maximum 20 in. x 40 in. Tabletop only.
88. **TRADITIONAL DOUBLE SAILOR'S VALENTINE.** Pair of hinged octagonal cases. Shells and/or sea life. Optional sentimental message and/or picture. Design to be created in the traditional Barbadian flat geometric Mosaic style incorporating cotton batting, paper dividers, majority of Caribbean shell types used, and other elements that were utilized in older valentines. Maximum 14 in. x 28 in. Tabletop only.
89. **NOVELTIES.** Animals, caricatures, etc. Shells and/or sea life. On single base or easel. Maximum 30 in. high x 24 in. wide. Tabletop only.
90. **FLOWER PICTURE.** Shells and/or sea life. Maximum 30 in. high x 24 in. wide. Tabletop easel required. See Artistic Rule 23.
91. **PICTURE OR MOSAIC OTHER THAN FLOWERS.** Shells and/or sea life. Maximum 30 in. high x 24 in. wide. Tabletop easel required. See Artistic Rule 23.
92. **MIRROR.** Shells and/or sea life. Maximum 30 in. high x 24 in. wide. May be a circle. Wall hung only.
93. **WREATH, NON-HOLIDAY.** Shells and/or sea life. Maximum 30 in. high x 24 in. wide. May be a circle, oval or heart shaped with open center. Wall hung only.
94. **MULTIMEDIA.** Photo, painting, or other artistic rendering. Shell related. No actual shells. Maximum 30 in. high x 24 in. wide. Tabletop easel required. See Artistic Rule 23.
95. **SHELL TABLE.** Must utilize shells and/or sea life as a major component. **Minimum 16 in. high x 15 in. deep x 15 in. wide.** Maximum 36 in. high x 30 in. deep x 42 in. wide. Cannot have drawers. **Must set directly on the floor.**
96. **SHELL BOX.** Box must use shells and/or sea life as a major component. Maximum 12 in. x 24 in. Tabletop only.
97. **MISCELLANEOUS.** Not applicable to any of the other classes. Maximum 30 in. high x 24 in. wide. Tabletop only.

**HOBBYIST CLASSES, ARTISTIC DIVISION SPECIAL AWARDS  
2019 SANIBEL SHELL SHOW**

- H1. MYRTLE WILLIAMS WEINSTEIN AWARD**  
Best shell flower exhibit in Classes 40 – 43.
- H2. GERTRUDE A. FORD AWARD**  
Best miniature flower arrangement in Class 44.
- H3. BEST PICTURE OR MOSAIC – HOBBYIST**  
Best entry in Classes 45, 59, and 60.
- H4. FLO IORIO AWARD**  
Best lamp in Class 46.
- H5. WANDA WILL AWARD**  
Best entry in Classes 48 and 49.
- H6. DOROTHY K. PUTNAM AWARD**  
Best mirror in Class 61.
- H7. BEST SINGLE SAILOR’S VALENTINE – HOBBYIST**  
Best Sailor’s Valentine in Classes 52 - 55.
- H8. BEST MINIATURE SAILOR’S VALENTINE – HOBBYIST**  
Best miniature Sailor’s Valentine in Class 53 - 54.
- H9. BEST DOUBLE SAILOR’S VALENTINE – HOBBYIST**  
Best Sailor’s Valentine in Classes 56 - 57.
- H10. BETTIE K. MCGOWAN AWARD**  
Best holiday exhibit in Class 51.
- H11. BEST SHELL-RELATED EXHIBIT – HOBBYIST**  
Best exhibit in Classes 50 and 63.
- H12. TERRI GOSSELIN AWARD**  
Best exhibit in Class 66.
- H13. DANIEL E. MALONE AWARD**  
Best Young Artist Exhibit Classes 67 and 68.
- H14. BEST IN SHOW – HOBBYIST**  
Best hobbyist exhibit in Classes 40 – 68.

**PROFESSIONAL CLASSES, ARTISTIC DIVISION SPECIAL AWARDS  
2019 SANIBEL SHELL SHOW**

**P1. BEST SINGLE SAILOR'S VALENTINE – PROFESSIONAL**

Best exhibit in Classes 82 - 86.

**P2. BEST DOUBLE SAILOR'S VALENTINE – PROFESSIONAL**

Best exhibit in Classes 87 and 88.

**P3. BILL JORDAN AWARD – PROFESSIONAL**

Best miniature Sailor's Valentine in Classes 83 and 84.

**P4. BEST MEDIUM SAILOR'S VALENTINE – PROFESSIONAL**

Best exhibit in Class 85.

**P5. BEST FLOWER EXHIBIT – PROFESSIONAL**

Best exhibit in Classes 70 – 73.

**P6. META NEUJAHR AWARD**

Best miniature flower arrangement in Class 74.

**P7. BEST PICTURE OR MOSAIC – PROFESSIONAL**

Best exhibit in Classes 75, 90 and 91.

**P8. BEST MISCELLANEOUS EXHIBIT – PROFESSIONAL**

Best exhibit in Class 97.

**P9. CAPT. TOM CLIFFORD AWARD**

Best in show – Professional Classes 70 – 97.

**COMBINED HOBBYIST AND PROFESSIONAL ARTISTIC CLASSES**

**HP1. JUDGE'S SPECIAL RIBBONS** – One award by each Artistic Judge to any Artistic Division exhibit.

**HP2. JUDGES' MERIT RIBBONS** – Awarded to a non-blue ribbon exhibit that the Judges agreed was noteworthy of recognition.

**HP3. PEOPLES' CHOICE AWARD** – Awarded to the Artistic exhibit voted most outstanding by the public.

**ARTISTIC DIVISION ENTRY FORM  
2019 SANIBEL SHELL SHOW**

• Early **DECEMBER** address • Please print

NAME: \_\_\_\_\_

MAILING ADDRESS: \_\_\_\_\_

CITY: \_\_\_\_\_ STATE: \_\_\_\_\_ ZIP: \_\_\_\_\_

PHONE: (December) \_\_\_\_\_ PHONE: (February) \_\_\_\_\_

Email: \_\_\_\_\_

If you are age seventeen or under, indicate age and grade: \_\_\_\_\_

LEAVE BLANK	CLASS NO.	TABLE TOP	WALL HUNG	OVERALL EXHIBIT SIZE			DESCRIPTION OF EXHIBIT
				HEIGHT (A)	DEPTH (B)	WIDTH (C)	

Electricity is provided only for a purpose integral to the exhibit. Exhibitor-provided supplemental/accent lighting is not permitted. Will your exhibit require electricity? \_\_\_\_\_ (Exhibitor must provide a 12 foot extension cord.)

I have read the Shell Show Rules and agree to abide by them. I understand that the Sanibel Community Association and the Sanibel-Captiva Shell Club accept no responsibility for loss or damage of any exhibit or part thereof.

All my exhibits consist of my work and do not include the work of anyone else (except for Class 201).

Is someone other than you bringing in or taking out your entry? \_\_\_\_ Who \_\_\_\_\_

SIGNED: \_\_\_\_\_ DATE: \_\_\_\_\_

Is this your first time exhibiting at the Sanibel Shell Show? YES: \_\_\_\_\_ NO: \_\_\_\_\_

Can you volunteer for two hours as a shell show host? IF YES, WHEN \_\_\_\_\_

**• MAIL ARTISTIC ENTRY FORM TO MARY BURTON AT THE ADDRESS BELOW •**

Before November 1, 2018	348 River Road, Cushing, ME 04563	Phone: (207) 354-2602
After November 1, 2018	558 Foxcreek Drive, Lehigh Acres, FL 33974	Phone: (239) 395-3626
<a href="mailto:marybsanibel@hotmail.com">marybsanibel@hotmail.com</a>		Cell: (561) 301-2971

**ENTRY FORM MUST BE RECEIVED BY FEBRUARY 14, 2019**



*You are cordially invited to join the judges, members of the Sanibel-Captiva Shell Club and the Shell Show Committee at the*

**82<sup>nd</sup> Annual Sanibel Shell Show  
Sanibel Shell Show Premiere**

*Your chance to view the exhibits and visit with the judges before the Shell Show opens*

**Wednesday, March 6<sup>th</sup>, 2019**  
*at the*  
**Sanibel Community House**  
2173 Periwinkle Way

**\$10 per person**

*Attendance is limited. Make your reservation early.*

**No reservations accepted after maximum number of reservations is reached or after February 27<sup>th</sup>.**

**Yes, I would love to join the festivities.**

Names of people attending \_\_\_\_\_

\_\_\_\_\_

Contact phone or email \_\_\_\_\_

Check enclosed in the amount of \$ \_\_\_\_\_

Please make check payable to: Sanibel-Captiva Shell Club.

Mail to: Sanibel-Captiva Shell Club, P.O. Box 355, Sanibel, FL 33957

(Do not send it with your Exhibit Form because that will delay your reservation from reaching the proper person.)

**Your admission to the Sneak Preview will be the nametag you receive at the reception.**